



S MINI

User Manual

Version 1.1



CONTENTS

01. IMPORTANT SAFETY INSTRUCTIONS	01
02. DEVICE AND ACCESSORIES	02
03. INSTALLATION	03
04. HOW TO USE	04
05. APCO TECHNOLOGY	05
06. BUTTONS AND LIGHTS	07
07. ACCESSORIES	09
08. SUVIOS APP	21
09. CLEANING/MAINTENANCE	25
10. PRODUCT SPECIFICATION	26
11. SUPPORT	26
12. WARRANTY	26
13. APPENDIX	27

01

IMPORTANT SAFETY INSTRUCTIONS

For your safety: Please read the safety instructions carefully before using the appliance the first time.

A warranty service is not applicable for damage or defects caused by noncompliance with the instructions for use. Keep these instructions for use close to the machine and pass them on to the next user.

※ WARNING

- This appliance is not intended for use by persons (including children) with reduced physical, sensory or mental capabilities, or lack of experience and knowledge, unless they have been given supervision or instruction concerning use of the appliance by a person responsible for their safety.
- Children should be supervised to ensure that they do not play with the appliance.
- This appliance contains a UV-C emitter
- Unintended use of the appliance or damage to the housing may result in the escape of dangerous UV-C radiation. UV-C radiation may, even in little doses, cause harm to the eyes and skin
- Appliances that are obviously damaged must not be operated.
- The replacement of the UV-C emitter by the user is not allowed..
- Do not use outdoors.
- Do not use unless all parts are present.
- Do not use the product where combustible gases or vapors are present.
- The product must be used in its upright position.
- Do not place foreign objects into or block the intake or exhaust airways (on either side of the product) to avoid damage to the product.
- Do not sit on or place heavy objects on the product.
- Prior to cleaning or other maintenance, the appliance must be disconnected from the supply mains.
- Appliances that are obviously damaged must not be operated.



1. This symbol on a product means that the product is covered by European Directive 2012/19/EU.
2. This symbol means that the product cannot be disposed of with normal household waste.
3. Inform yourself about the local separate collection system for electrical and electronic products and batteries.
4. Follow local rules and never dispose of the product and batteries with normal household waste.
5. Correct disposal of old products and batteries helps prevent negative consequences for the environment and human health.

02

DEVICE AND ACCESSORIES

What is in the box



Smini
(Wind Shield included)



Power / Charging
cable



Quick Start Guide

※ Please use the power adapter that supports 5V2A or above. While Smini is charged by battery box with batteries, please use the power adapter that supports 5V3A or QuickCharge (QC) type.

Compatible accessories (available separately)



Wall/Ceiling
Mount



Desktop Stand



Leather
Lanyard



Battery Box
(Batteries not included)

* Please use flat top
18650 Li-ion battery

03

INSTALLATION

1



Connect the cable to 5V2A(or above) power adapter, and plug the power adapter into the power socket. Plug the power/charging cable into the Smini power jack

2



Press the power button

04

HOW TO USE

Upright



Desktop with Desktop Stand



Mobile Use with Battery Box



Hanging with Leather Lanyard



Ceiling Mount with Wall/Ceiling Mount



Wall Mount with Wall/Ceiling Mount



APCO module (APCO, Advanced PhotoCatalysis Oxidation)

Through the most advanced methods, it decomposes contaminants into H_2O , CO_2 and other inorganic molecules, returning to the environment without any pollution. Together with Optoelectronics experts and Medical experts, SUIOS has created Smini with this unique APCO module inside. It can even eliminate germs very effectively during high speed air flow and on surface to even further remove odors, smell caused by smoke.

3 Patented key designs

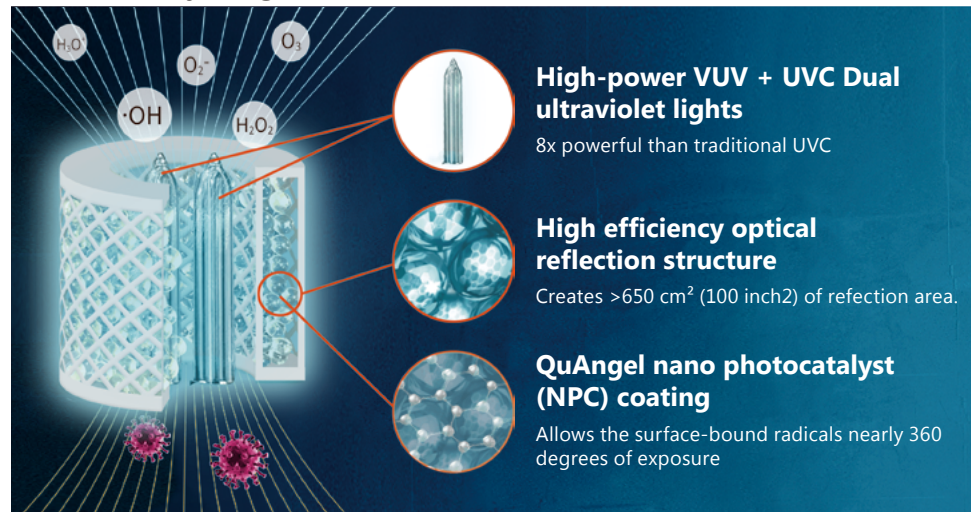

High-power VUV + UVC Dual ultraviolet lights:

8x powerful than traditional UVC

APCO module:

All new developed high efficiency optical reflection structure creates $>650\text{ cm}^2$ (100 inch²) of reflection area to increase reaction efficiency

QuAngel coating:

QuAngel nano photocatalyst (NPC) coating has been proved by experiments to effectively inhibit 99.99% of the new coronavirus and common germs in various environments

3 phases sanitization

1. Step 1 - Kill 99.9% germs in the airflow in 0.026 sec

The APCO chamber inside Smini contains VUV (vacuum ultraviolet) which increased 8.3x more efficiency than traditional UVC. With the dual ultraviolet light (VUV+UVC) and unique optical reflection structure, 99.9% of germs in the airflow through chamber will be killed within 0.026 second.

2. Step 2 - Decompose the germs on the surfaces in a safe and pollution-free way.

QuAngel NPC coating materials optimally react with multiple wavelengths of U.V. energy and then produce trillions of hydroxyls and organic oxidants for further purification. Hydroxyls and organic oxidants have a powerful oxidation effect, which can decompose microorganisms and chemical pollutants. Such effect of deodorization and sterilization is the same as the chain oxidation reactions caused by sunlight on the object's surface.

3. Step 3 - Chain oxidation reaction

Same as sunlight reaction on the surface, after the purification process, the contaminants are decomposed into water, oxygen, and carbon dioxide molecules, returning to the environment without any pollution.

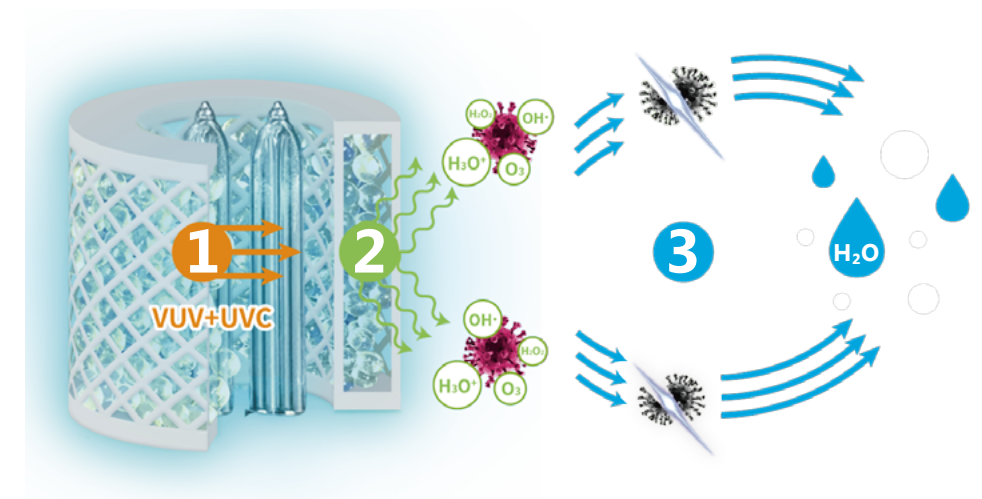

06







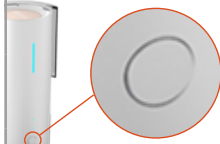



Buttons and lights



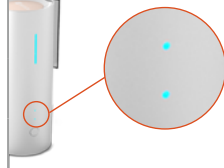

Button

	Description
 Power button	Power on: In 'power-off' state, press the power button to turn on Smini
	Power off: In 'power-on' state, press and hold the power button for 1-2 seconds and then release it to turn off Smini
	Mode switch: In 'power-on' state, press shortly the power button to switch among LOW, HIGH and TURBO modes

LED lights





	lights	Description
 APCO status		Power is off
		APCO is working
		APCO is not working
 Mode indication		Power is off
		Low
		High
		Turbo
		Fan is not working

※While you activate Smini in SUVIOS APP successfully, the BLUE light  mentioned above will become GREEN 

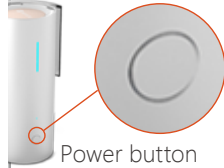
Use with APP

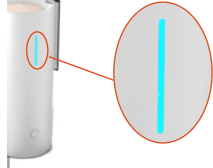
Please read page 21 「08 SUVIOS APP」

	Description
 Power button	APP pairing mode: Press and hold the power button for 5 seconds until the LED indicator flashes and hear beeper. Release the power button. The Smini is ready for APP pairing

	Light	Description
 APCO status	 Blue light flashes slowly	APP pairing mode. Off automatically when no pairing within 20 seconds.
	 Yellow light flashes slowly	Connection with home wifi
	 Yellow light flashes quickly	Connection with internet
	 Green light is on	APCO is working

Accessories

• Desktop Stand

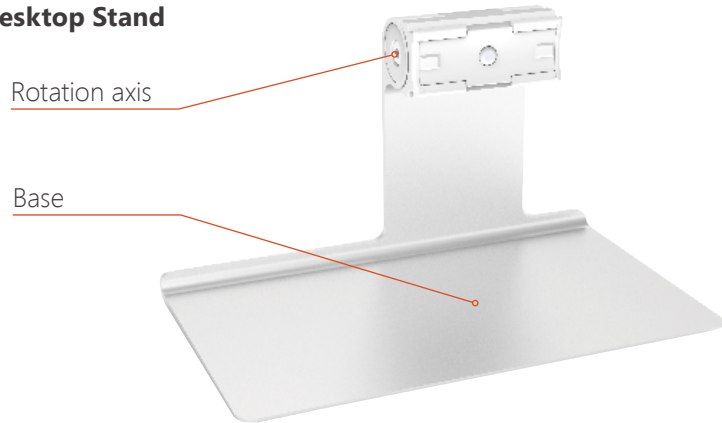

• Battery Box



* Please use flat top 18650 Li-ion battery.

Battery power	LED lights	Description
 * Press to show indication	● Green light is on	Power level60~100%
	● Yellow light is on	Power level20~60%
	● Red light is on	Power level0~20%
Charge power	LED lights	Description
 	● Green light is on	Fully charged
	⚡ Green light flashing	Power level60~100%
	⚡ Yellow light flashing	Power level20~60%
	⚡ Red light flashing	Power level0~20%

• Leather Lanyard



• Ceiling Mount

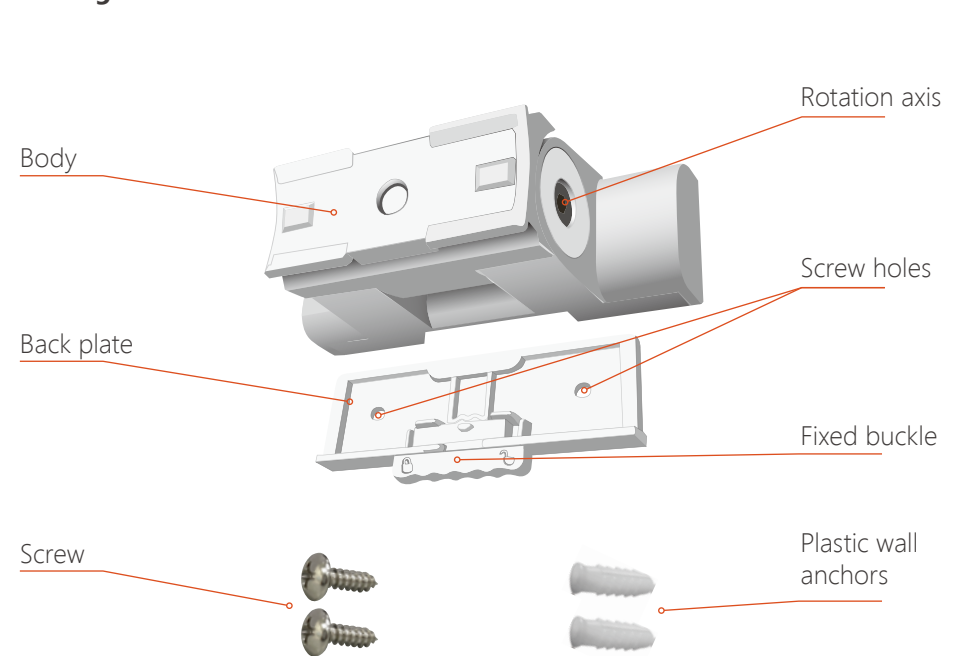

Application scenarios• **Desktop Stand**

Applied with Desktop Stand. Can be placed on table, office bureau, or building entrance...etc.

• **Battery Box**

Attach Battery Box without power cable.
For travel or at public transport

• **Leather Lanyard**

With Leather Lanyard and Battery Box.
Hang it in cloakroom, bathroom, babywagen, Cart...

• **Ceiling Mount**

Mount on ceiling or wall with Wall Mount.
Wall of bathroom, office or ceiling of storage room...etc

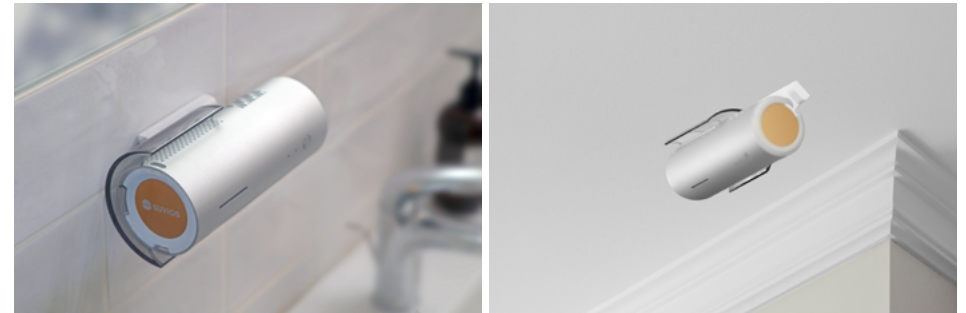

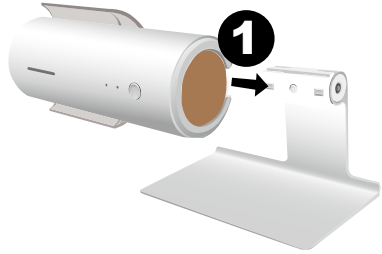
Install and remove• **Install Desktop Stand**

Press the base of the Desktop Stand with your hand to stabilize it, align the groove on the back of the Smini with the tenon of the Desktop Stand, and install it from left to right until you hear a click

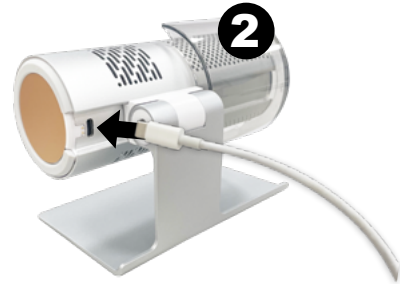

Connect the cable to 5V2A(or above) power adapter, and plug the power adapter into the power socket. Plug the power/charging cable into the Smini power jack

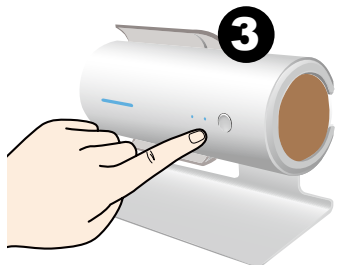

Press the power button shortly

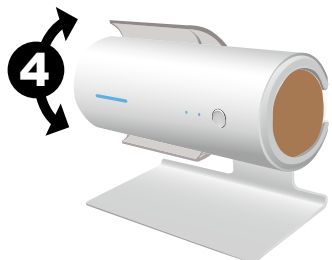

Press the base of the Desktop Stand with one hand to stabilize it, and hold the Smini with another hand, you can adjust the angle according to your wish.

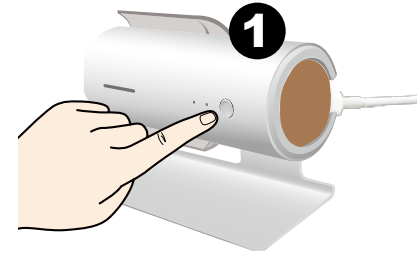
• **Remove Desktop Stand**

Press and hold the power button for about a second and release it to turn off the Smini

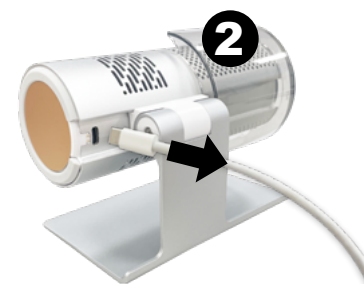

Remove the power/charging cable from the Smini

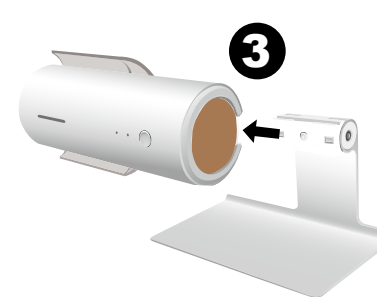

Hold the base of the Desktop Stand with your hand to stabilize it, slide the Smini to the left to remove it from the Desktop Stand

• Install Battery Box

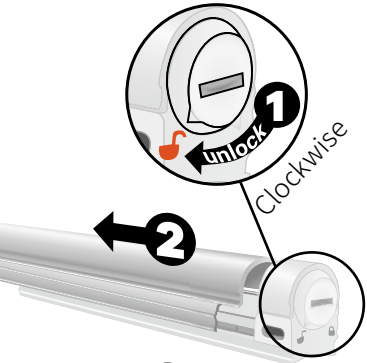

Using a coin as an aid, turn the battery box knob clockwise ↻ to the end (the knob groove is completely horizontal) to unlock

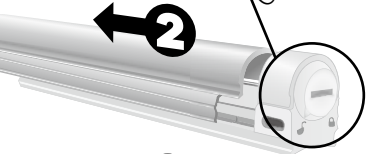

Grasp the position of the USB-C charging hole with one hand, and slide the upper cover of the Battery Box with another hand to remove

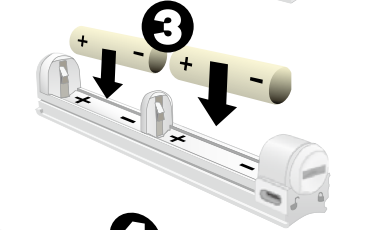

Confirm the + and - directions of the battery and mark on the Battery Box. Insert 18650 flat head lithium battery with +/+ and -/-

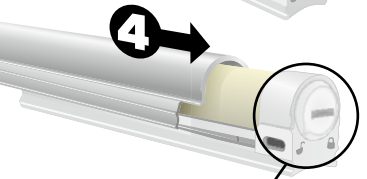

Grasp the position of the USB-C charging hole with one hand, and replace the top cover of the Battery Box with another hand.



Using a coin as an aid, turn the Batter Box knob counterclockwise ↻ to the end (the knob groove is completely vertical) to lock

Counterclockwise



Hold the Smini with one hand and pull the Wind Shield upwards with another hand

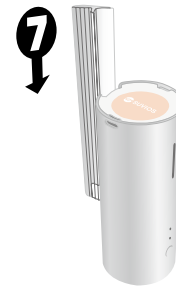

The button of the Batter Box is facing up, align with the groove on the back of the Smini and then install it



Shortly press the power button to turn on the Smini

• Remove Battery Box

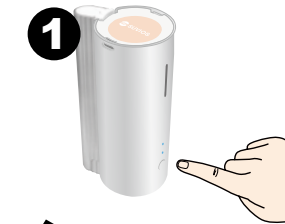

Press and hold the power button for about a second and release it to turn off the Smini

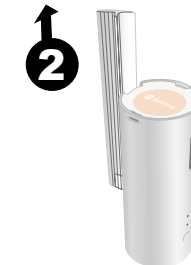

The Battery Box is removed upwards



The TOP mark on the Wind Shield is facing upwards, and the inside of the Wind Shield is aligned with the groove on the back of the Smini. Install it from top to bottom. Finally, push it a little bit harder into the groove to confirm that the Wind Shield is stable and will not fall down

- Install Leather Lanyard



Thread the Leather Lanyard through the top hole on the Smini device

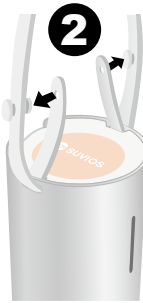

Insert the opening on the belt into the buckle



a. Take it with you - use with the Battery Box
b. Fixed place - use with Wind Shield and power cord



Shortly press the power button to turn on the Smini

- Remove Leather Lanyard



Press and hold the power button for about a second and release it to turn off the Smini



a. Take it with you - remove the Battery Box
b. Fixed place - remove Wind Shield and power cord



Detach the Leather Lanyard from the left and right buckles



Remove the Leather Lanyard

07

ACCESSORIES

• Install Wall/Ceiling Mount



Push the lock button under the wall mount to the right to unlock

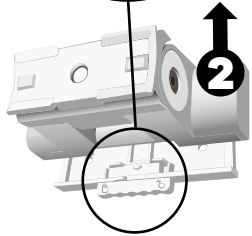

The main body of the wall mount is separated from the back panel

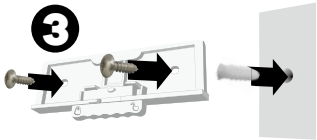

After installing the plastic wall anchors into the wall hole, lock the screw into the back plate hole

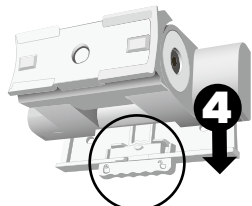

Reinstall the main body of the wall mount to the back panel



Push the lock key to the left to lock

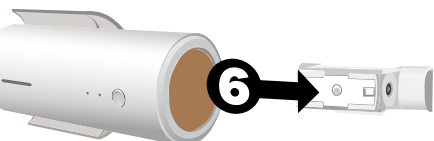

Align the groove on the back of the Smini with the tenon of the wall mount and install it

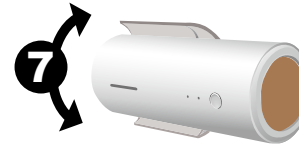

Adjust the angle as needed

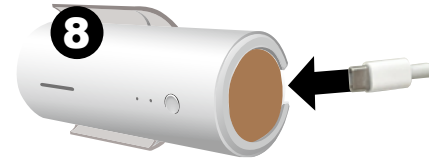

Connect the cable to 5V2A(or above) power adapter, and plug the power adapter into the power socket. Plug the power/charging cable into the Smini power jack

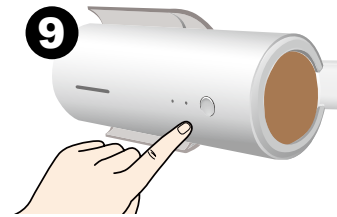

Shortly press the power button to turn on the Smini

• Remove Wall/Ceiling Mount

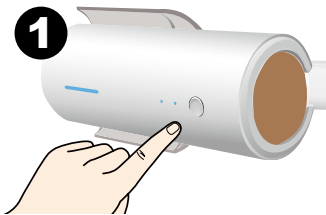

Press and hold the power button for about a second and release it to turn off the Smini

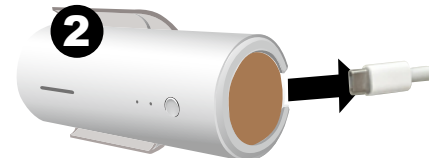

Remove the power/charging cable from the Smini

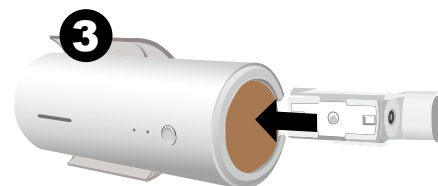

Remove the Smini from the wall mount from right to left

Download SUVIOS APP

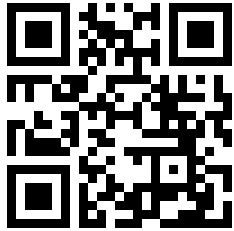

Scan the QR code to download the SUVIOS APP, or search for "SUVIOS" on Google Play / App Store

※ Please contact local SUVIOS dealers for the official launch time of SUVIOS APP

Register a SUVIOS account

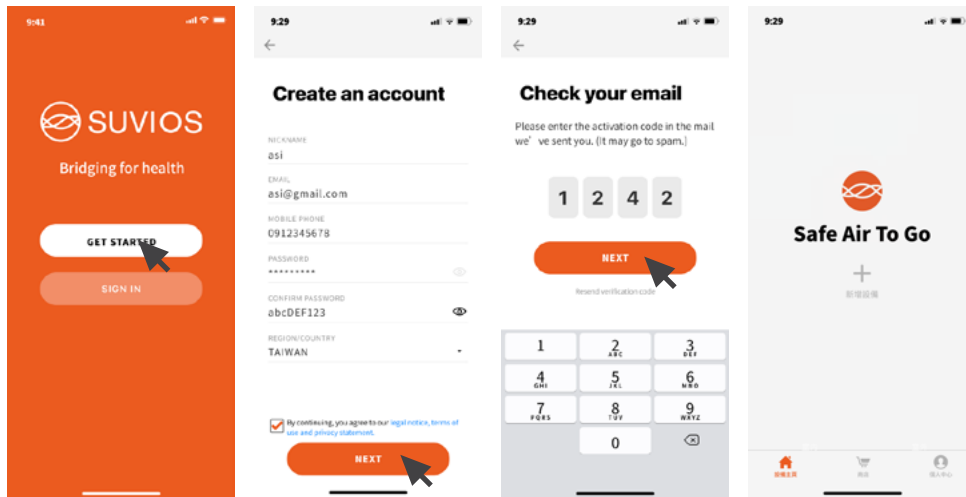

1. Click "Start"

2. Fill all requested data in and click "Next"

3. Check email inbox for verification code first and fill it in APP. Then click "Next"

4. After the code is verified, it will login automatically.

Add device

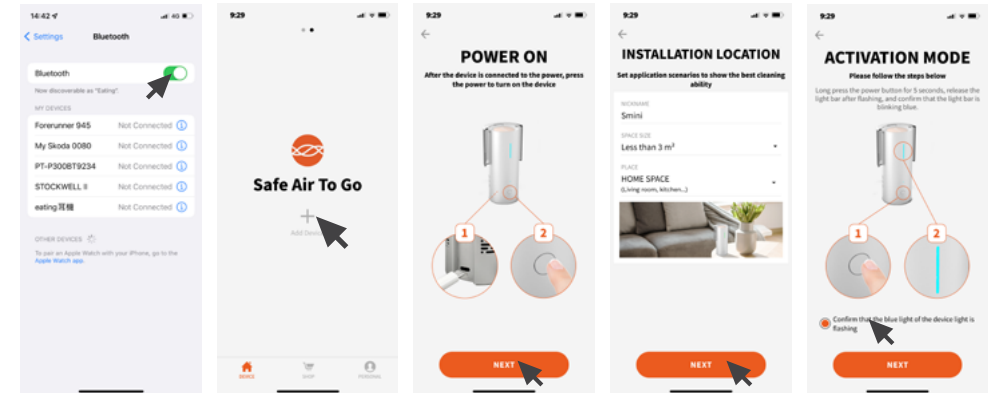

1. Control if the bluetooth of smartphone is ON

2. Select "Device" in the menu and click "Add Device"

3. Follow the APP instructions to turn on the device, then click "Next"

4. Set the information of the place where you want to place the Smini, then click "Next"

5. Press and hold the Smini power button for about 5 seconds until the blue light of the long light bar flashes and then release. At this point Smini enters the enabled mode, then click "Next"

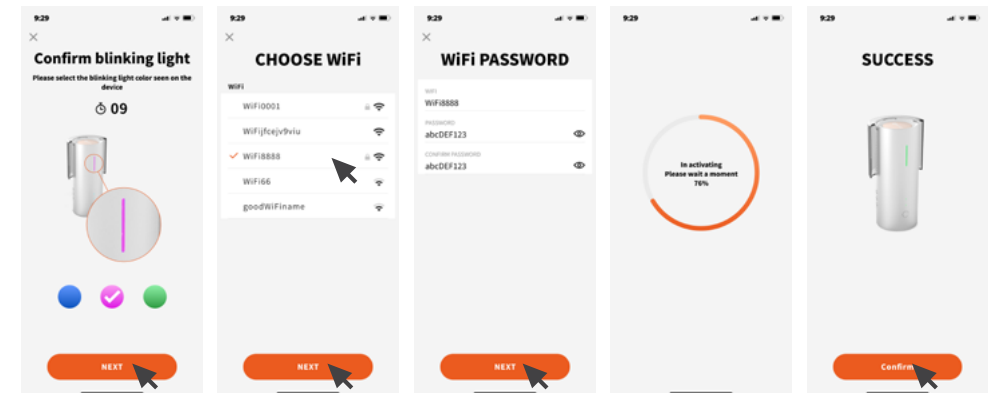

6. Confirm the flashing light color of Smini, and select the corresponding color on the APP, then click "Next"

7. Select your home WIFI network on the APP, then click "Next"

8. Enter the WIFI password, then click "Next"

9. Activating, please wait.

10. The activation is successful, click "Confirm"

SUVIOS APP interface



※ SUVIOS APP will continue to be optimized, the actual interface and functions are subject to the actual downloaded APP

FAQ

• Failed to add device to APP

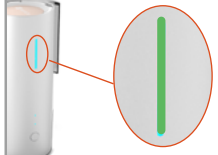
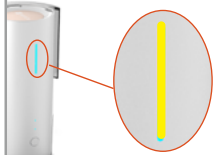
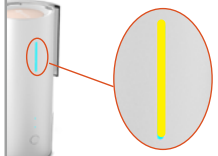
	Description	How to process
 Green light is on	Smini has been successfully activated, but the APP fails due to network reasons	Your device has been successfully activated, but the mobile phone may be temporarily disconnected from the Internet. Please press the confirm button below and return to the home page to see your newly activated device.
 Yellow light flashes slowly	Your Smini cannot connect with the WiFi router	Your device cannot connect to the WiFi router. The possible reasons for the failure are as follows: 1. The WiFi password is entered incorrectly. 2. WiFi is a hidden SSID, please do not hide the SSID first. 3. Other reasons. Please use the app to send a problem report and contact customer service. After eliminating possible errors, press and hold the power button to shut down, and the activation process will be performed again.
 Yellow light flashes quickly	Unable to connect to the Internet	Your device cannot communicate with the server. The possible reasons for the failure are as follows: 1. The WiFi router cannot connect to the Internet, please confirm your network connection. 2. For other reasons, please use the App to send a problem report and contact customer service. After eliminating possible errors, press and hold the power button to shut down, and the activation process will be performed again.

• How to deal with the change of WiFi at home?

Pair the Smini with the APP again, the steps are as follows:

1. Press and hold the power button for more than 5 seconds when the Smini is powered on, release it after hearing the pressing sound, and the APCO indicator light flashes blue.
2. Follow the "Add Device" method on the previous page to re-add the device

09

CLEANING/MAINTENANCE

1



Press and hold the power button for about a second and release it to turn off the Smini

2



Remove the power/charging cable from the Smini

3



Use a vacuum cleaner to absorb the dirt on the air inlet, or wipe it with a slightly moistened cloth. If there is serious dirt on the surface, please use a neutral detergent

※ The machine is strictly forbidden to wash with water

To prevent danger, always remove the power supply during cleaning and maintenance!

※ If the product is damaged, please contact the original factory. Do not repair it by yourself to avoid any risk

10

PRODUCT SPECIFICATION

Power Consumption	Max 8 W
Voltage	5V2A
Wireless	2.4G WiFi / BLE
Noise	< 45 dB(A)
Dimensions	Ø 68 x 160 mm
Net Weight	460 g

11

SUPPORT

If you have any questions, please contact us

Telephone: +31(0)15-8000 240

E-mail : support@brisecare.com

Twitter global: @Brisecare

12

WARRANTY

One-year warranty for entire device from date of purchase.

RoHS declaration

Equipment name: Sanitizer Type designation (Type): Smini						
Unit	Restricted substances and its chemical symbols					
	Lead (Pb)	Mercury (Hg)	Cadmium (Cd)	Hexavalent chromium (Cr ⁺⁶)	Polybrominated biphenyls (PBB)	Polybrominated diphenyl ethers (PBDE)
Power cord set, internal wiring	○	○	○	○	○	○
Circuit board related components	○	○	○	○	○	○
Fan	○	○	○	○	○	○
APCO module	○	○	○	○	○	○
Plastic components	○	○	○	○	○	○
Metal parts	○	○	○	○	○	○
<p>Note 1: “Exceeding 0.1 wt %” and “exceeding 0.01 wt %” indicate that the percentage content of the restricted substance exceeds the reference percentage value of presence condition.</p> <p>Note 2: “○” indicates that the percentage content of the restricted substance does not exceed the percentage of reference value of presence.</p> <p>Note 3: The “—” indicates that the restricted substance corresponds to the exemption.</p>						